

SPECIFICATIONS	
CONTACT CARRIER MATERIAL	NYLON OR TPU
MOLDED HEAD MATERIAL/COLOR	TPU/BLACK
CONTACT MATERIAL/PLATING	BRASS/GOLD
COUPLING NUT MATERIAL/PLATING (P1)	BRASS/NICKEL
LOCKING SLEEVE (J1)	POM, SNAP LOCK
RATED CURRENT [A]	2.0 A
RATED VOLTAGE [V]	125 VAC/VDC
OUTER JACKET MATERIAL/COLOR	PVC/BLACK
CONDUCTOR INSULATION MATERIAL	PVC
NUMBER OF CONDUCTORS [AWG]	4x26 AWG
TEMPERATURE RATING	-40°C TO +105°C (-40°F TO +221°F)
PROTECTION CLASS	MEETS NEMA 1,3,4,6P AND IEC IP67

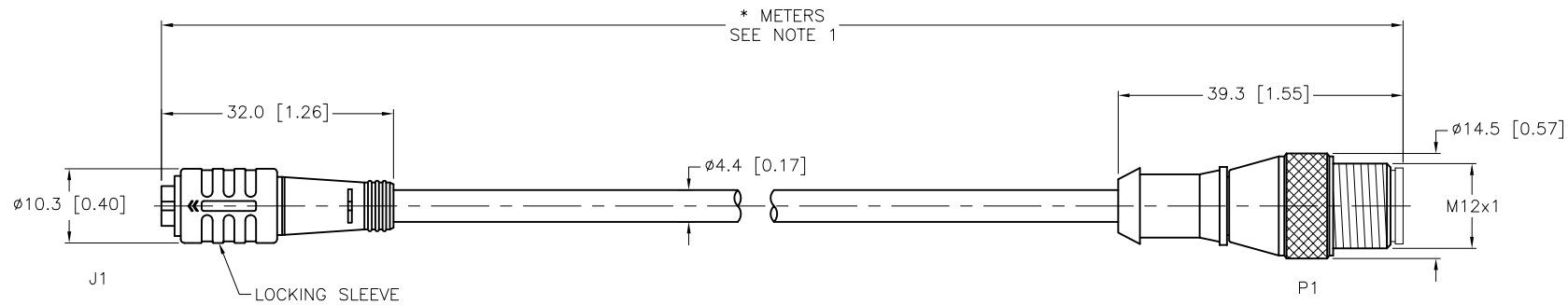

CABLE LENGTH	TOLERANCE
ALL LENGTHS	+ 4% (OR 50mm) OF LENGTH - 0% (OR 0mm) OF LENGTH WHICHEVER IS GREATER
STRIP LENGTH	TOLERANCE
0-7mm	±0.5mm
8-29mm	±1.0mm
30-49mm	±2.0mm
50-69mm	±3.0mm
70-100mm	±4.0mm
OVER 100mm	±5.0mm

- NOTES:
- "*" INDICATES CABLE LENGTH IN METERS. CONTACT TURCK TO ORDER SPECIFIC LENGTHS.
 - "/S760" DESIGNATES BLACK CABLE JACKET.
 - "/S771" DESIGNATES BLACK MOLDED PLUG BODIES.

SOURCE DRAWING - FOR REFERENCE ONLY

RELATED DOCUMENTS	3RD ANGLE PROJECTION	THIS DRAWING IS CONFIDENTIAL AND THE PROPERTY OF TURCK INC. USE OF THIS DOCUMENT WITHOUT WRITTEN PERMISSION IS PROHIBITED.	<p>3000 CAMPUS DRIVE MINNEAPOLIS, MN 55441 1-800-544-7769 (763) 553-7300 (763) 553-0708 fax turck.com</p>	
1.		DRFT RDS	DATE 02/28/12	DESCRIPTION PKG 4Z-*--RS 4.4T/S760/S771
2.		APVD T.S.	SCALE 1=1.0	
3.	ALL DIMENSIONS DISPLAYED ON THIS DRAWING ARE FOR REFERENCE ONLY	UNIT OF MEASUREMENT MILLIMETER [INCH]		IDENTIFICATION NO.
4.		CONTACT TURCK FOR MORE INFORMATION		REV A
MATERIAL	DO NOT SCALE THIS DRAWING	FILE: 777015625		
FINISH		SHEET 1 OF 1		

A	DRAWING RELEASE	RDS	03/02/12	
REV	DESCRIPTION	BY	DATE	ECO NO.