

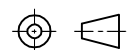

| CABLE LENGTH | TOLERANCE* |
|--------------|---|
| ALL LENGTHS | + 4% (OR 50mm) OF LENGTH - 0% (OR 0mm) OF LENGTH WHICHEVER IS GREATER |
| STRIP LENGTH | TOLERANCE* |
| 0-7mm | ±0.5mm |
| 8-29mm | ±1.0mm |
| 30-49mm | ±2.0mm |
| 50-69mm | ±3.0mm |
| 70-100mm | ±4.0mm |
| OVER 100mm | ±5.0mm |

*UNLESS OTHERWISE SPECIFIED

SOURCE DRAWING - FOR REFERENCE ONLY

- NOTES:
- "*" INDICATES CABLE LENGTH IN METERS. CONTACT TURCK TO ORDER SPECIFIC LENGTHS.
 - "S3537" DESIGNATES SAFETY EXHAUST VALVE WIRING FOR SAFETY BLOCK.

| | | | | | |
|---|---|--|--|---|---|
| RELATED DOCUMENTS 1. 2. 3. 4. | 3RD ANGLE PROJECTION  | THIS DRAWING IS CONFIDENTIAL AND THE PROPERTY OF TURCK INC. USE OF THIS DOCUMENT WITHOUT WRITTEN PERMISSION IS PROHIBITED. | 3000 CAMPUS DRIVE MINNEAPOLIS, MN 55441 1-800-544-7769 (763) 553-7300 (763) 553-0708 fax www.turck.us |  | DRFT NF DATE 02/04/19 APVD E.S. SCALE 1=1.0 DESCRIPTION RK 4.4T-*--RS 4.4T/S3537 |
| MATERIAL | SEE SPECIFICATION | UNIT OF MEASUREMENT | IDENTIFICATION NO. REV A | | |
| FINISH | SEE SPECIFICATIONS | MILLIMETER [INCH] | | | |
| CONTACT TURCK FOR MORE INFORMATION | | DO NOT SCALE THIS DRAWING | FILE: 777042820 | SHEET 1 OF 1 | |

| | | | | |
|-----|-----------------|----|----------|---------|
| A | DRAWING RELEASE | NF | 02/13/19 | |
| REV | DESCRIPTION | BY | DATE | ECO NO. |